

Gardner
Denver

ROTARY SCREW GAS BARES

SS Series



Experience Reliability & Productivity

Natural Gas Rotary Screw Compressors

Durability Measured in Decades

Since 1859, Gardner Denver has designed and built the industry's highest quality products. To better serve your needs, Gardner Denver continually builds products to maximize efficiency and durability. Our rotary screw compressors, for natural gas applications, are no exception to this tradition. Our rotary gas compressors are constructed using advanced technology, careful engineering, micro-precision manufacturing, and total quality management. These inherent features make Gardner Denver the choice when reliability and total value are the criteria.

Gardner Denver Natural Gas Compressors 55-720 HP (peak)

Gardner Denver's SS Series Natural Gas Compressors are offered in ranges from 15-720 horsepower. Our rotary screw gas ends are well suited for natural gas compressor applications. All Gardner Denver gas compressors are constructed of ferrous metal. No yellow metals are used in the gas end construction. This allows the Gardner Denver Rotary Gas Compressor to be used in virtually any natural gas application.

Rotary screw gas ends are designed to be used in a lubricant flooded system. Coolant/lubricant flowing through the Rotary Gas Compressor protects the internal components from corrosive vapors.

Optional drive arrangements for Gardner Denver Rotary Gas Compressors range from plain face and keyed shaft for "C" and "D" flanges and SAE engine mounts for engine-driven applications.



TAPERED ROLLER
THRUST BEARINGS

NODULAR
IRON ROTORS

ALL STEEL CYLINDRICAL
ROLLER BEARINGS
FOR RADIAL LOADS

DIRECT DRIVE
(SSY - Gear Driven)

All Ferrous Construction
Bare Compressor

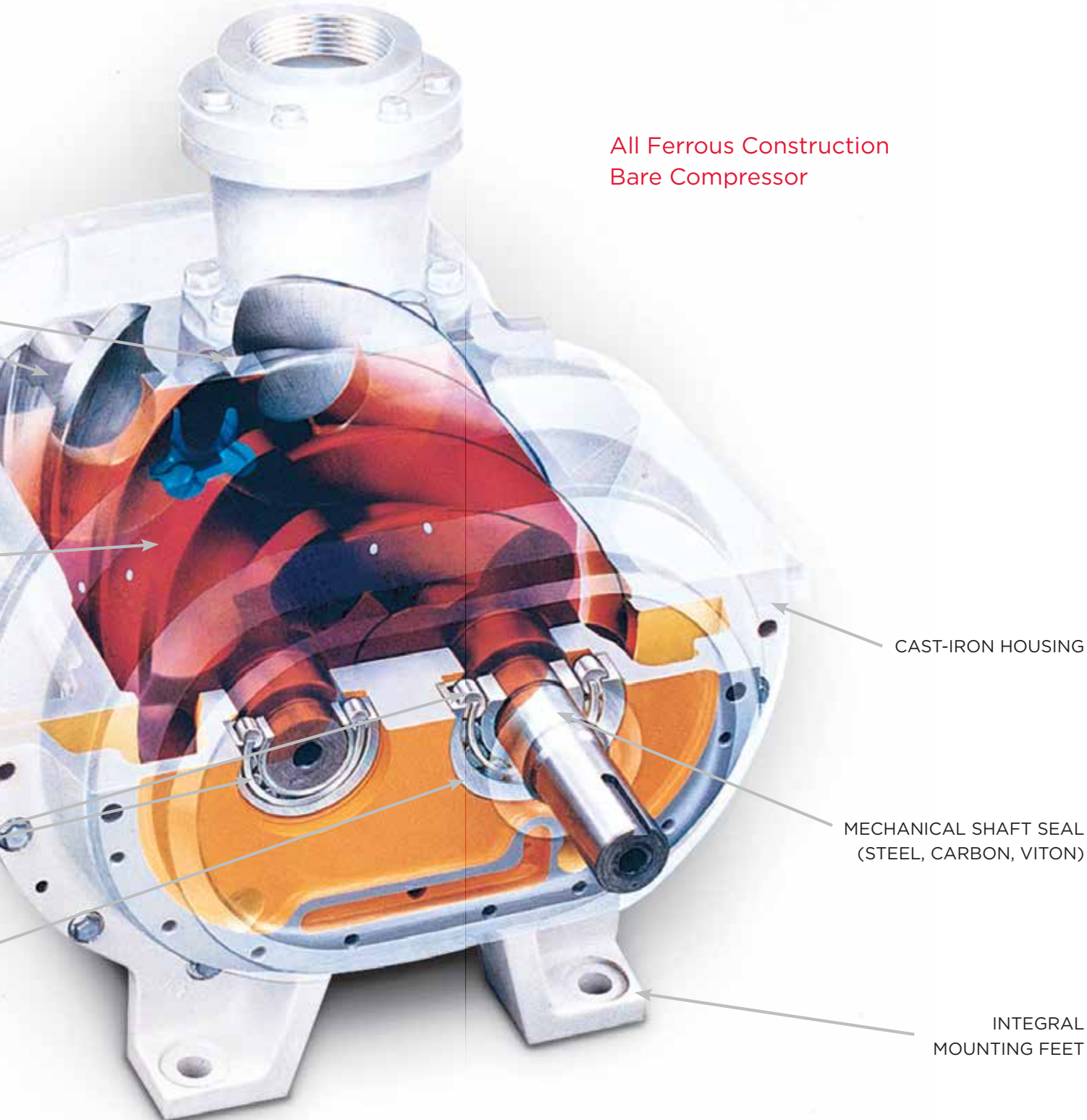

CAST-IRON HOUSING

MECHANICAL SHAFT SEAL
(STEEL, CARBON, VITON)

INTEGRAL
MOUNTING FEET

Performance Driven Durability

For Rugged Natural Gas Applications

Component Materials

Gardner Denver oil flooded screw gas compressors contain no brass, copper materials or buna rubber.

Larger Rotors are the prime reason Gardner Denver compressors save you money. The durability and efficiency of a compressor package are largely a function of the size of the gas end. The most important compressor efficiency measure to consider is the volume of compressed gas delivered and the corresponding brake horsepower required to produce that volume.

Although smaller gas ends can be manufactured at a lower cost, their operating efficiency, life expectancy and maintenance periods can be proportionally shorter. For a smaller gas compressor to deliver the same volume, the rotor must turn faster.

Volume Index

The Gardner Denver Volume Index system is a unique system discharge port that allows for correct geometry. The V.I. was designed to gain optimized efficiency of the unit and to match the curvature of the rotor; the result is no efficiency penalty. There are no additional maintenance issues with this feature, it is easily converted to match any application.



Features

- Contains No Brass or Copper Materials
- Vibration Sensor Mounting Locations
- Large Bearings
- Viton O-Rings
- Mechanical Shaft Seal
- Quick Change VI (SSU "C" & SSY "C")

Options

- Four V.I. Ratios Per Model
- Output Shaft (SSH, SSF, SSE and SSM)
- SAE Housing
- Direct Mounted Oil Pump
- Turn Valve® Capacity Control
- "C" or "D" Flanges
- ANSI 150 & ANSI 300 Discharge Flanges

Available Accessories

- Separators/Receivers
- Inlet Valves
- Oil Filters
- Oil



Proven Efficiency, Longer Life

Natural Gas Rotary Screw Compressors

Premium Features

Gardner Denver offers more features per horsepower, more features per dollar, more options to match your job—and better efficiency to save power costs. The savings of owning and operating a Gardner Denver Rotary Gas Compressor begin to build the minute you turn it on—and keep building throughout its long, productive life.

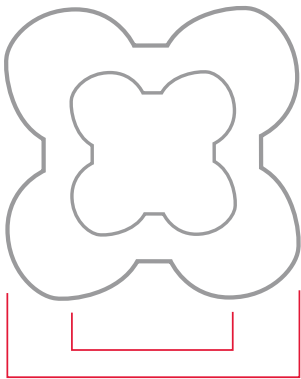

Patented KYPHO asymmetrical rotors minimize internal leakage, deliver 3–5% greater efficiency.

Up to 41% larger diameter rotors extends compressor life and lowers overall operating costs.

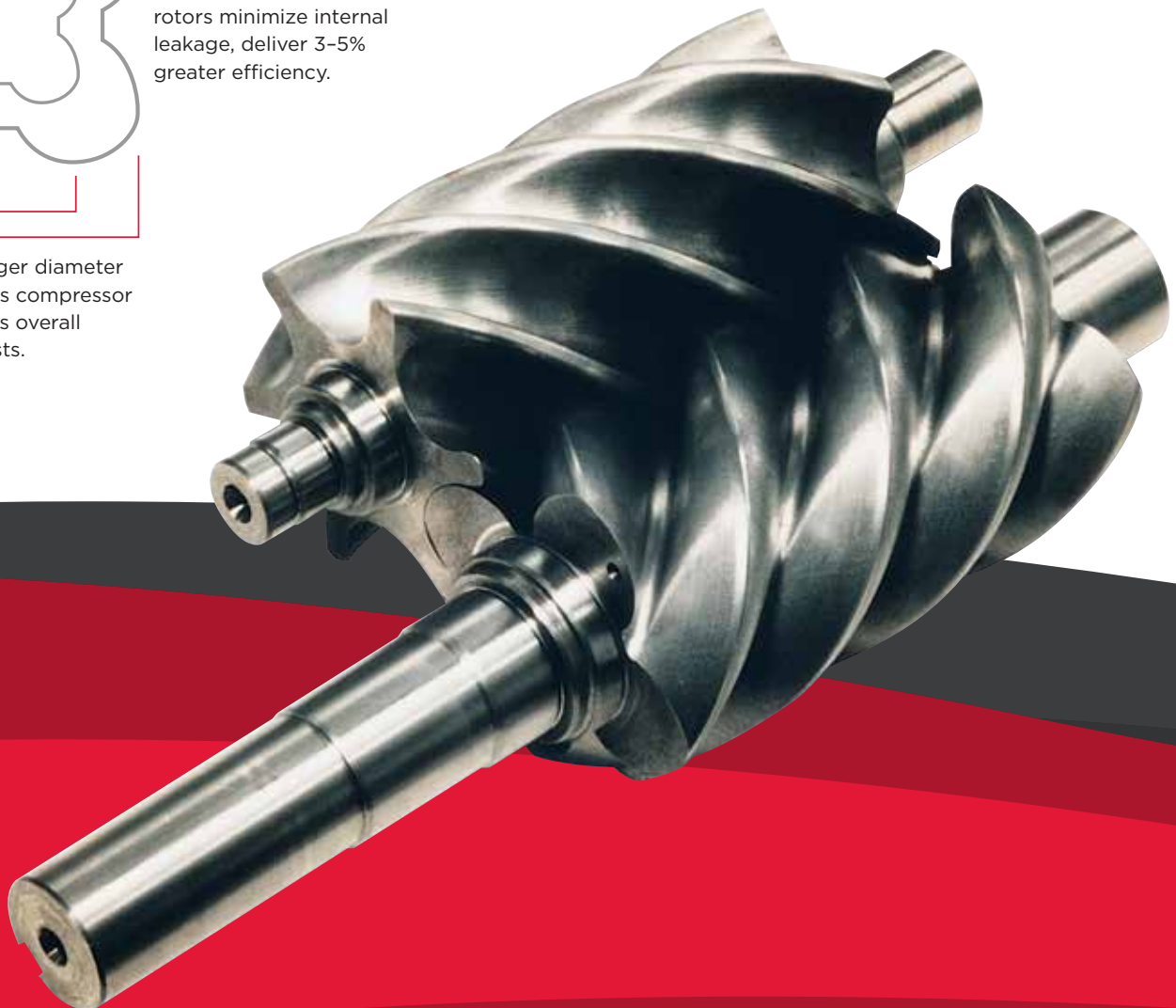

Exclusive Gardner Denver Features

All Gardner Denver Rotary Screw Compressors contain a unique combination of outstanding features:

Exclusive KYPHO Rotor Profile returns greater efficiency over its operating range and delivers a 3% to 5% operating efficiency advantage over standard rotor designs. Its asymmetrical rotor shape inherently provides a tighter seal between the grooves of the rotors to reduce slippage, eliminate vibration and increase efficiency.

Direct-Driven, Rotary Gas Compressor with lower operating speeds for longer life and lower operating costs.

Gear-driven, Rotary Gas Compressors allow for optimum matching to engine peak performance speeds.

Rotors up to 41% Larger in diameter than other compressor brands deliver operating speeds among the lowest in the industry. Low speeds extend compressor life, reduce compression heat and contribute to overall lower operating cost.

Long-Life Bearings mean longer service. All Gardner Denver compressors are designed with large, cylindrical roller bearings at the inlet and time-proven tapered roller bearings at the discharge. Gardner Denver uses bearings as much as 170% larger than competitive models.



Maximize Volume Efficiency

With Over-Sized Rotors & a Patented Profile

Driver/Power Requirements

Engines and standard motors provide adequate starting torque for most applications. A discharge check valve and blowdown valve should be installed to prevent loaded start against system pressure.

The packager is responsible for the torsional compatibility of the compressor, the driver and the coupling.

INERTIA VALUES LB.-FT²

MODEL	SSE	SSF	SSH	SSM	SSP	SSQ	SSU	SSY
WR2	0.5	1.6	3.57	7.24	15	17.7	36.23	130.18 to 255

GAS FRAMES - MODEL AND PERFORMANCE DATA

MODEL	MALE MOTOR (MM)	RPM RANGE	MAXIMUM SUCTION PSI	PEAK HORSEPOWER	MAXIMUM DIFFERENTIAL PRESSURE	MAXIMUM W.P.
SSE	121	1263-5524	50	55	350	375
SSF	153	999-4369	50	65	350	375
SSH	177	863-3777	50	90	350	375
SSM	206	742-3245	50	135	350	375
SSP	227	673-2945	50	180	350	375
SSQ	248	616-2695	50	240	250	300
SSU	296	1161-3226	50	460	200	250
SSY	370	636-3462	50	720	200	250

GAS FRAMES - CONFIGURATIONS

MODEL	DRIVE	ROTATION	AUX. SHAFT	TURN VALVE	INTERNAL VOLUME RATIOS			
SSE	Direct	Clockwise	Yes	No	1.8	2.2	3.0	4.6
SSF	Direct	Clockwise	Yes	No	1.8	2.2	3.0	4.6
SSH	Direct	Clockwise	Yes	Yes	1.8	2.2	3.0	5.2
SSM	Direct	Clockwise	Yes	Yes	1.8	2.2	3.0	5.2
SSP	Direct	Clockwise	No	Yes	1.8	2.2	3.0	5.2
SSQ	Direct	Clockwise	No	Yes	1.8	2.2	3.0	4.6
SSU*	Direct	Clockwise	No	Yes	2.8	3.2	3.7	4.6
SSY*	Gear	Clockwise	No	Yes	2.8	3.2	3.7	4.6

*Note: Field Changeable VI

Typical Gas Compressor System

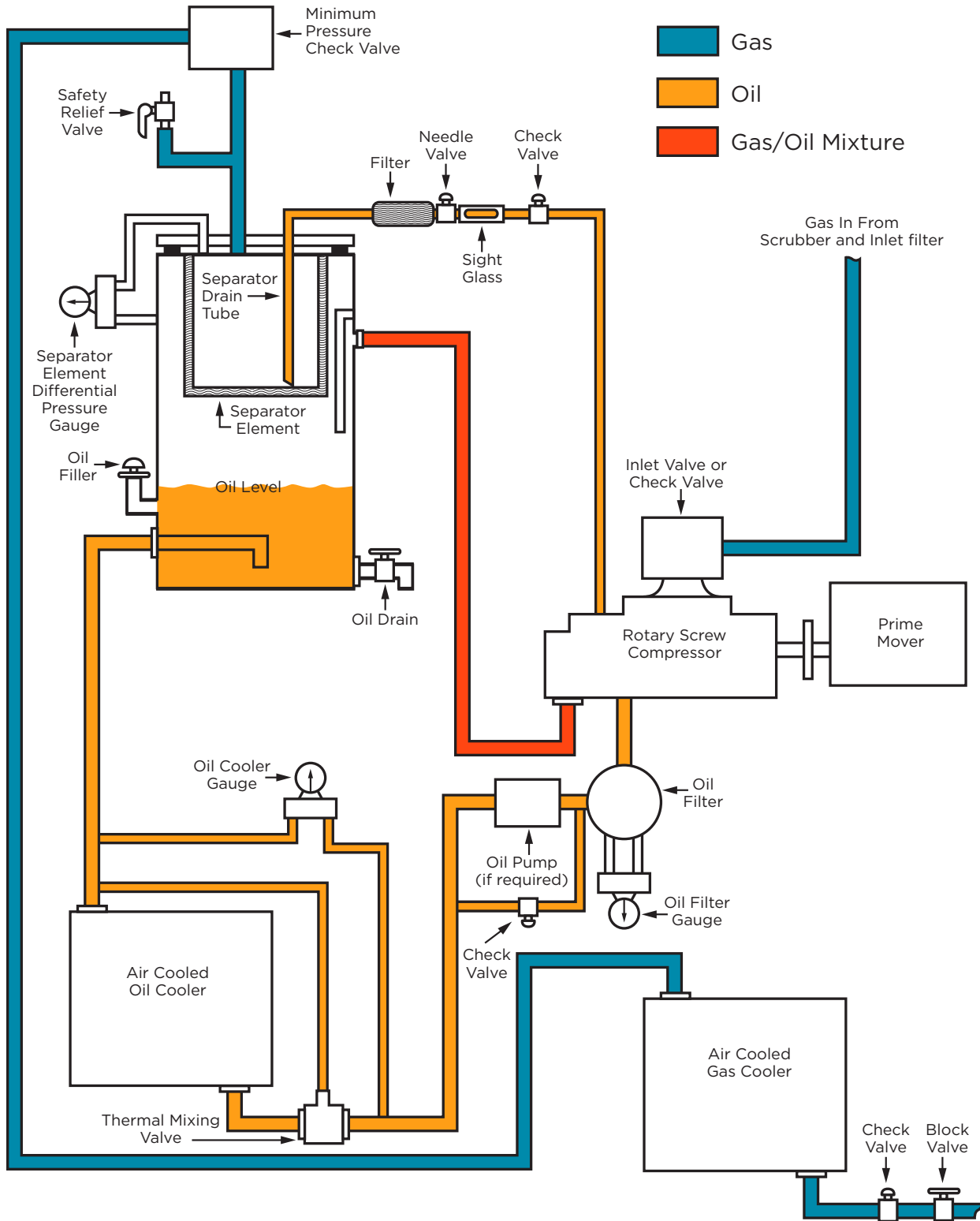

Maximum Control Flexibility for Optimum Results



Bearings—Primary Factor in Determining Overhaul Intervals

Once a manufacturer chooses to build a certain size gas end, maximum bearing size is limited by the distance between the rotors. A small gas end is unable to use a bearing large enough to give you the durability you want. A large diameter rotor results in slower speeds and allows for the use of larger, longer-lasting bearings. Larger bearings with larger surface area are better able to withstand foreign particles which might find their way into the bearing housings.

Rotor Size & Speed

Both small, high-speed, fast running gas ends and large, slow-running gas ends are available in the same horsepower. Each might be considered for the same application since each will deliver the same volume of gas at the same pressure. But larger gas ends deliver compressed gas more efficiently.

Why? As rotor diameter increases, gas output per revolution increases faster than the leakage area (which is the clearance between the rotors and the gas end housing).

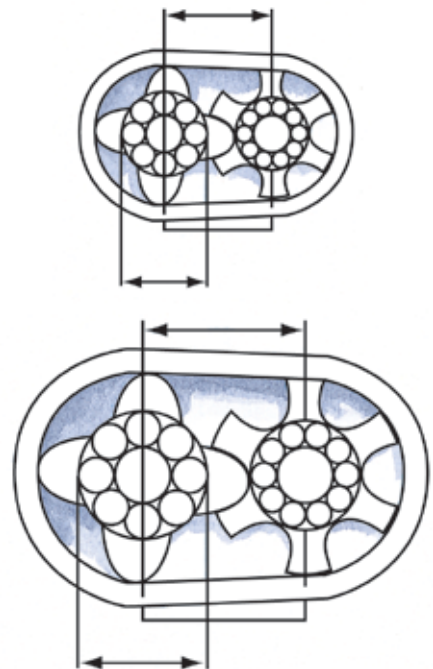

Gas end size determines
bearing size

Capacity Control Systems

Control methods are used to match the capacity to the requirements of the application.

Basic Types of Capacity Control Systems

1. Speed Control

Utilizing an engine or variable speed electric motor driver allows gas output to be controlled with compressor RPM adjustment. Gardner Denver Gas Rotary Screw Compressor operating speeds are well matched with today's engine speeds.

2. Rotor Length Adjustment

This system utilizes a patented Turn Valve to expose a greater or lesser number of ports cast in the cylinder wall to vary the seal-off point in the cylinder.

Unneeded gas that has entered the cylinder is allowed to return to the inlet before being compressed.

3. Inlet Throttling

This system uses a throttle or valve at the inlet of the compressor to restrict the opening and admit only the required volume of gas.

“Quick Change VI Option” by Gardner Denver

Available on our models SSYG99C and SSUG99C allows for fast VI changes, in the field, on site, to match varying operating conditions. The four (4) available VI settings can be changed in minutes without the need for special tools, or the need to replace compressor components.

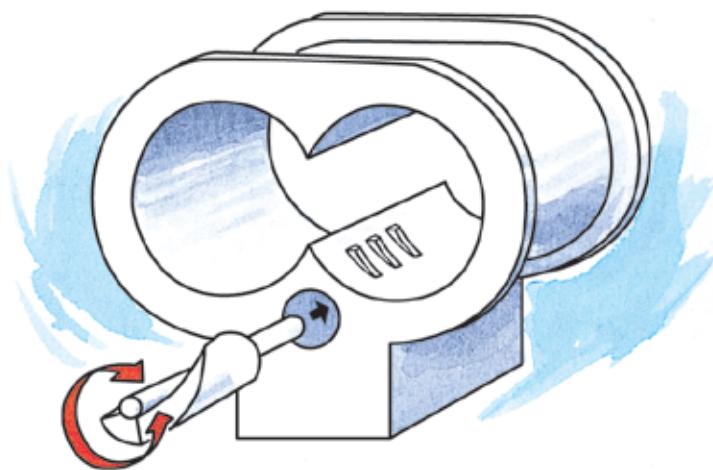
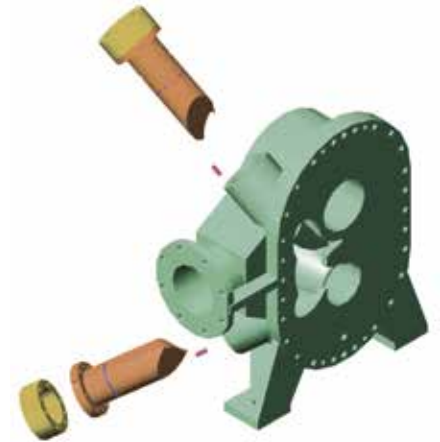

Turn Valve



Turn Valve Cylinder



	% VOLUME	% POWER
	90	93
	85	88
	80	85
	75	81
	70	78
	65	75
	60	72
	55	70
	50	67
	45	65
	40	64

Models SSH, SSM, SSP, SSQ, SSU and SSY are equipped with turn valves to vary capacity down to 40% of full volume.

Full One Year Warranty

With every quality Gardner Denver Rotary Gas Compressor you receive a complete one year warranty, not just a 30-90 day promise. Gardner Denver has been in business over 140 years and will be there tomorrow for continued support.



Large Parts Inventory

Gardner Denver maintains a large inventory of genuine OEM Rotary Gas Compressor replacement parts. Replacement parts are available to you when you need them, whether you are performing a scheduled gas end rebuild or need parts in a hurry. Count on genuine Gardner Denver replacement parts and the Gardner Denver Team commitment to you.

Dedicated Repair Facility

Gardner Denver's Repair and Re-Manufacturing Operations is located in Sedalia, Missouri. At the facility, Gardner Denver factory trained service technicians use quality OEM parts to service and repair your Gas Compression Equipment quickly and efficiently to the exacting standards required. We understand the importance of getting your equipment up and running as soon as possible so our repair parts are stocked along with complete frames for quick response to your field repair needs.



Gardner Denver

Gardner Denver, Inc.

1800 Gardner Expressway
Quincy, IL 62305
866-440-6241

www.gardnerdenverproducts.com

©2015 Gardner Denver, Inc. Printed in U.S.A.
GS-NGAS-FAM 1st Ed. 4/15

